

Series 6900

Preferred Replacement Garden Window



PARTNER OF THE YEAR

Andersen Corporation, including its subsidiary Silver Line Building Products LLC, earned the 2010 ENERGY STAR® Partner of the Year award.

Silver Line[®]
WINDOWS • DOORS
an Andersen Company



Preferred Replacement Garden Window



Series 6900 Garden Window

Features & Benefits:

- Insulated glass helps save energy and helps reduce heating and cooling costs
- Fusion-welded frame and sash create strong, weathertight corners
- Heavy-duty frame provides solid construction
- Operating window opens out for excellent ventilation
- Fully assembled for a faster and more weathertight installation
- Dual weatherstripping virtually eliminates drafts
- Glass shelf allows additional light to enter your home while providing extra decorating space

The Silver Line® Series 6900 preferred replacement garden window is a wonderful enhancement to any home. This eye-catching design is a great way to bring the outdoors inside and an ideal place to display your plants and watch them bloom. The Series 6900 garden window does more than an ordinary window; it reaches out from the room and brings light into your home. With three different styles to choose from it is a unique addition to any room.

Color

These Silver Line® vinyl windows are available in white and beige. The color is consistent throughout the frame and sash, making scratches virtually invisible.

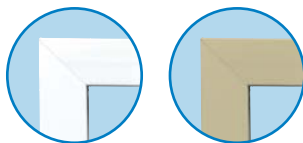

White

Beige

Energy Efficient Glass Options

All Silver Line windows and doors are available with energy efficient, dual-pane glass options to achieve the level of comfort and energy savings you are looking for. This window offers:

LoE2 Glass – Designed to efficiently and transparently reflect heat, this glass helps keep your home warmer in the winter and cooler in the summer. This can help reduce your energy bills while still ensuring exceptional clarity.

LoE3 Glass – This highly efficient glass helps reflect even more heat, resulting in increased comfort and energy savings year-round.

Argon Gas Fill – An odorless, non-toxic gas that helps reduce heat loss, helping to save on heating costs.

Tempered Glass – A heat-treated glass that shatters into pebble-sized pieces instead of larger shards to reduce the risk of injury. This glass is standard for the roof and shelf of our garden windows. It is optional on the sides and front.



PARTNER OF THE YEAR

Andersen Corporation, including its subsidiary Silver Line Building Products LLC, earned the 2010 ENERGY STAR® Partner of the Year award.

Hardware

Color coordinated to match the window and designed to provide easy operation. The specially designed handle folds away giving you more space to display plants and collectibles.



Folding Handle



Lock

* Available with flat grilles only

Printing limitations prevent exact color duplication. See your Silver Line supplier for actual color samples.

Silver Line does not warrant that inert gas infills (such as Argon gas), sealed in the insulated glass unit at the point of manufacture, will not dissipate over time. Silver Line reserves the right to change product designs, specifications, details and pricing at any time without prior notification.

Design Options

We offer several styles and size options to fit your space.

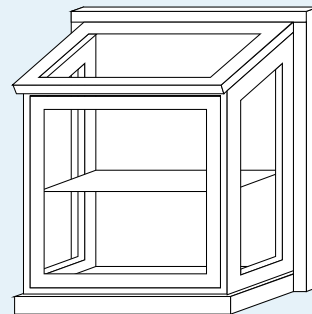

6901

Single Awning

Width: 28" to 48"

Height: 28" to 48"

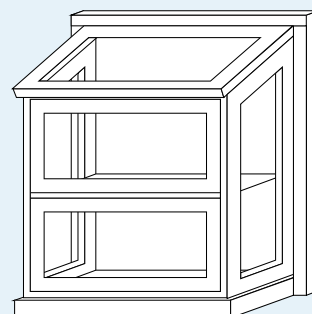

6912V

Twin Vertical Awnings

Width: 28" to 48"

Height: 48-1/4" to 72"

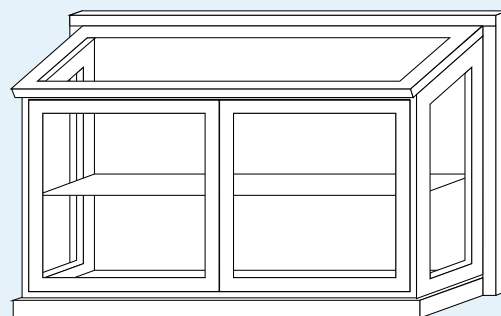

6912H

Twin Horizontal Awnings

Width: 48-1/4" to 78"

Height: 28" to 48"

Series 6900 Garden Window Features

Let the sunshine in and keep the weather out. Designed to enhance your home and engineered for durable, energy efficient performance.

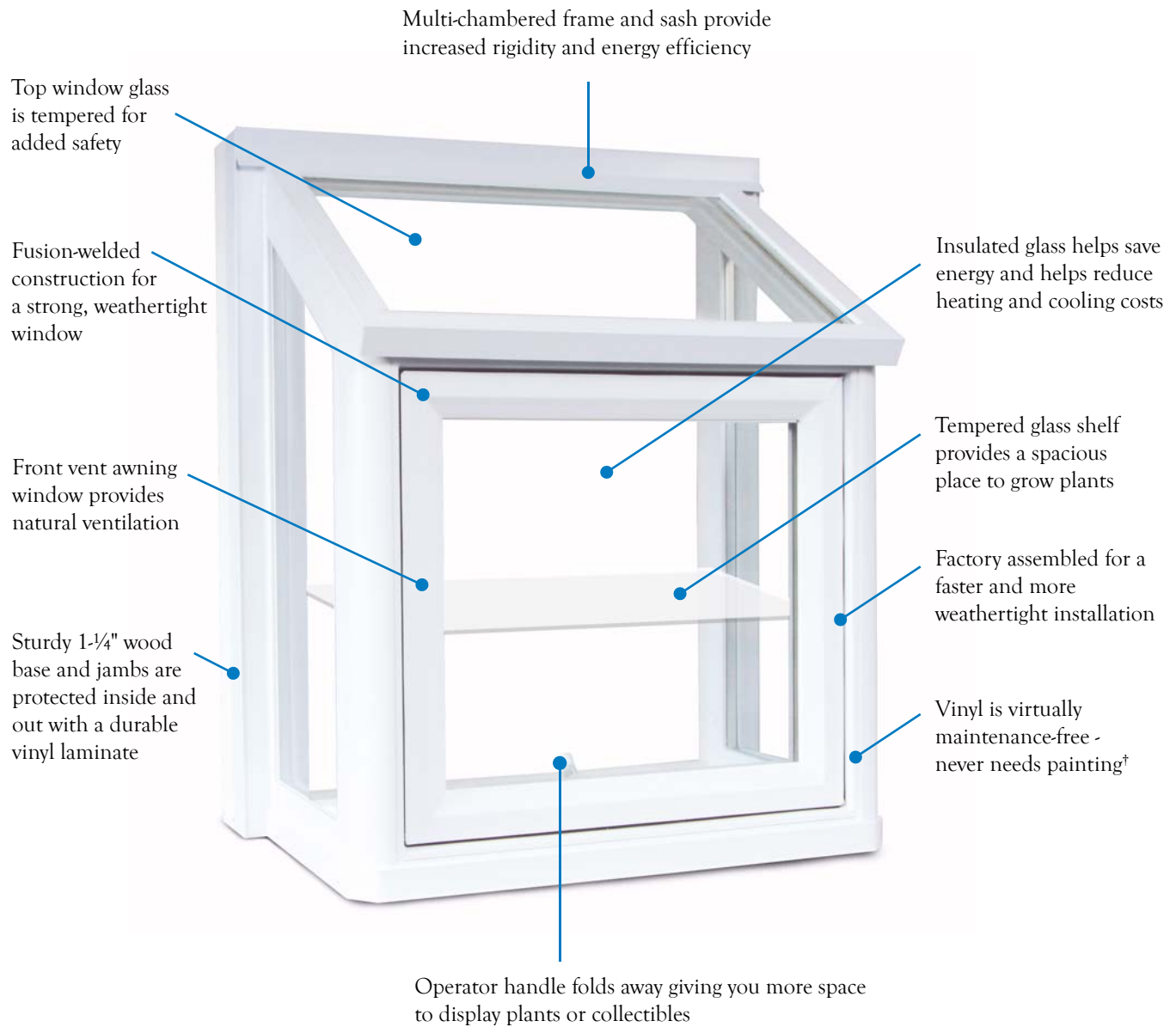

For more information on Silver Line® windows and doors visit us at www.silverlinewindows.com or call us at 800.234.4228



This document was printed using paper from responsibly managed forests, soy-based inks and 100% Green-E certified Wind Energy.

† - See the limited warranty for details. "Silver Line" and all other marks where denoted are trademarks of Silver Line Building Products LLC. © 2010 Silver Line Building Products LLC. All rights reserved.